

ecoStorm Plus 1000

high performance-cost effective
Stormwater Treatment System

For the removal of sediments, heavy metals and nutrients.

FREYTECH INC.

ecoStorm
plus

Version 1.3.2.20

Stormwater Filtration is vital to maintaining the quality of our finite water supply

Freytech presents ecoStorm plus, an affordable stormwater filtration system designed to remove sediments, heavy metals and nutrients.

Surface water runoff contains significant concentrations of heavy metals and other soluble pollutants.

Structural Stormwater

treatment systems are effective in removing sediments, but do not remove solubles such as heavy metals and nutrients (phosphates and nitrates).

By using various physical and chemical processes, the ecoStorm plus Filtration System effectively AND affordably removes BOTH solids and dissolved substances, including:

- Heavy metals (zinc, copper, lead, cadmium, chromium, nickel)
- Hydrocarbons (mineral oils, polycyclic aromatic hydrocarbons)
- Nutrients such as phosphorous and nitrates



See why ecoStorm plus is the most cost effective stormwater filtration system on the market, setting new standards for stormwater regulatory requirements

- In addition to filtration, the system utilizes chemical transformation, precipitation and sorption (ion exchange) to remove a variety of pollutants (heavy metals, hydrocarbons) from stormwater
- More effective and affordable than conventional filters utilizing stainless steel, activated carbon or zeolithes
- Upstream sediment removal combined with self-cleaning filters reduces maintenance intervals and costs
- Easy installation saves time and money — single-structure design comes pre-assembled to jobsite, reducing footprint and excavation costs
- Has undergone extensive laboratory and field-testing with proven results
- Patented filters can be modified to accommodate various applications and flowrates

Removal Efficiency*

Removal efficiencies for all relevant pollutants far exceed both North American and European Standards for stormwater run-off.

Total Suspended Solids (TSS)	>95%
Zinc (Zn)	>80%
Lead (Pb)	>95%
Copper (Cu)	>90%
Hydrocarbons	>98%
Phosphorous	>70%
Nitrates	*

* detailed test reports are available upon request

ecoStorm plus Treatment Process

All ecoStorm plus units are equipped with a central overflow and maintenance pipe to handle peak flow rates and allow access to the sediment storage chamber. While ecoStorm plus is typically designed for gravity treatment of stormwater drainage, it has the flexibility to accommodate other methods of pollutant delivery. The patented substrate can be modified to accommodate various applications and flowrates.

Sedimentation

Sediments are removed from stormwater by gravitation and trapped in the base section of the ecoStorm plus unit. A small amount of sediment will accumulate temporarily on the lower surface of the filter (PlusFilter). The design of the ecoStorm plus system allows self cleaning.

Filtration

Vertical filtration in the pollution control pit and constant immersion in water of the PlusFilter prevents formation of a film on the lower side of the filter, which might otherwise lead to clogging.

Adsorption

Pollutants like hydrocarbons and dissolved heavy metals are adsorbed by the modified porous filter material.

Chemical precipitation

The PlusFilter buffers the pH of the stormwater, which is typically acidic, hence promoting precipitation and accumulation of dissolved substances. The fine pores of the filter allow water to seep slowly through the media providing greater opportunity for interaction between water and the alkaline composition of the filter.



Sedimentation

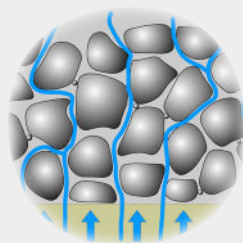

Filtration

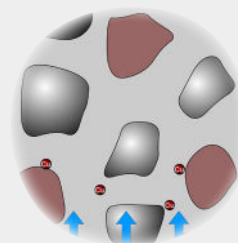

Adsorption

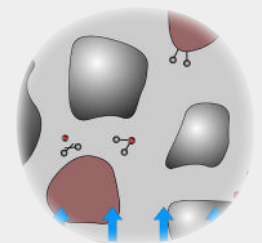

Precipitation

Specifically designed for low-cost and easy maintenance

The frequency of sediment removal and filter replacement are dependent on site-conditions and pollutant loads. Sediment, which may contain heavy metals removed during the cleaning process, is disposed either manually or by mechanical suction.

Permeable substrate (PlusFilter) in the Pollution Control Pit are self-cleaning and are expected to remain effective for long periods (up to 5 years depending on pollutant loads) without replacement. However, new filters should be considered at more frequent intervals where pollution loads are heavy. Replacing filters is an easy and inexpensive process.

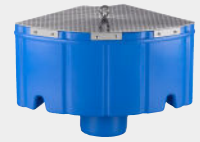

ecoStorm plus filter

Designed for a variety of applications

- Treatment of stormwater run-off from metal roofs
- Surface water runoff from streets, highways and parking lots



Metal roof run-off

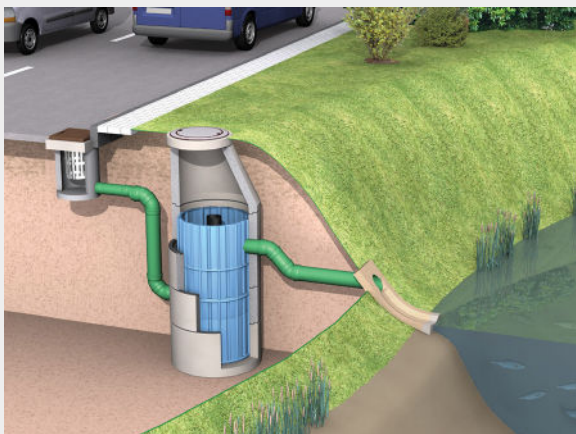

Run-off from highways

ecoStorm plus is ideal for new construction or retrofit applications including:

- Parking lots
- Treatment of run-off from metal roofs (Copper, Zinc and others)
- Industrial manufacturing facilities
- Commercial/retail developments
- Municipal/residential drainage improvements
- Transportation/maintenance facilities
- Water quality improvement of ponds and lakes

ecoStorm plus 1000 working principle

1. The rainwater from the connected area is fed into the base section of the filter housing. The tangential inlet generates a radial flow pattern.

2. The hydrodynamic separator converts turbulent waters into a radial laminar flow pattern, generating particle sedimentation, particularly of the sand fraction.

3. This takes place over an inlet to the lower section of the filter shaft. The sediment is retained in a sediment storage chamber below the separator. The sediment trap can be withdrawn for cleaning, and has an integral cleaning port to the side to ease dirt removal, (see 4).

4. In the central section of the filter housing is the actual filter, Filter Roof. The filter element filters out the fine materials in an up-flow process and dissolved materials are precipitated and adsorbed. The filter is backwashed from above. When exhausted the filter is easily exchanged.

5. The filter element is easily pulled up and removed from the shaft housing.

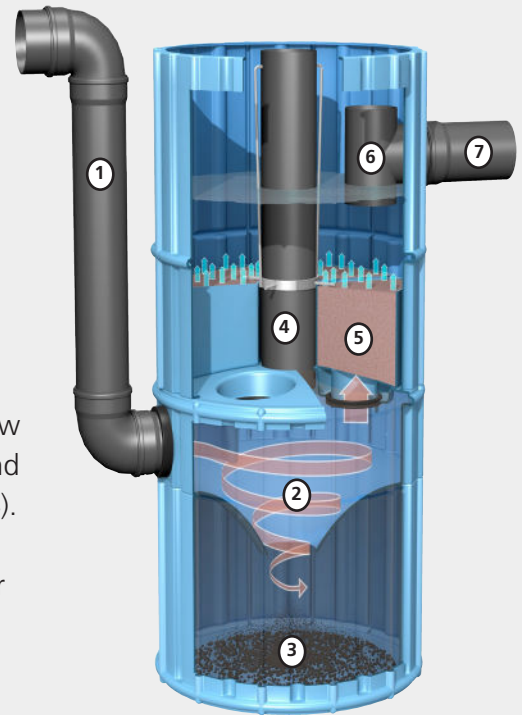

1. Rainwater Inlet
2. Hydrodynamic Separator
3. Sediment collection chamber
4. Cleaning port for sediments
5. Filter Element with overflow pipe and removal handle
6. T-Outlet pipe
7. Outlet to storm sewer or soakaway system

Parameter	Unit	Non metal roof		Copper roof		Zinc roof		Parking lot, residential street		main road, distributor		Aims of LAWA	drinking water	See-page	eco-Storm plus
		from	to	from	to	from	to	from	to	from	to	permissible limit	permissible limit	control value	Aim
Physico-chemical parameters												90-Perzentil			
Electr. conductivity	[uS/cm]	25	270	25	270	25	270	50	2400	110	2400	-	2500	-	<1500
pH value	[-]	4,7	6,8	4,7	6,8	4,7	6,8	6,4	7,9	6,4	7,9	-	6,5-9,5	-	7,0-9,5
Nutrients															
Phosphorous (Pges)	[mg/l]	0,06	0,5	0,06	0,5	0,06	0,5	0,09	0,3	0,23	0,34	-	-	-	0,2
Ammonium (NH ₄)	[mg/l]	0,1	6,2	0,1	6,2	0,1	6,2	0,0	0,9	0,5	2,3	-	0,5	-	0,3
Nitrate (NO ₃)	[mg/l]	0,1	4,7	0,1	4,7	0,1	4,7	0,0	16,0	0,0	16,0	-	50,0	-	
Heavy metals															
Cadmium (Cd)	[µg/l]	0,2	2,5	0,2	1,0	0,5	2,0	0,2	1,7	0,3	13,0	1,0	5,0	5,0	<1,0
Zinc (Zn)	[µg/l]	24	4880	24	877	1731	43674	15	1420	120	2000	500	-	500	<500
Copper (Cu)	[µg/l]	6	3416	2200	8500	11	950	21	140	97	104	20	2000	50	<50
Lead (Pb)	[µg/l]	2	493	2	493	4	302	98	170	11	525	50	10	25	<25
Nickel (Ni)	[µg/l]	2	7	2	7	2	7	4	70	4	70	50	20	50	<20
Chromium (Cr)	[µg/l]	2	6	2	6	2	6	6	50	6	50	50	50	50	<50
Organic substances															
polynuclear aromatic hydrocarbons (PAK)	[µg/l]	0,4	0,6	0,4	0,6	0,4	0,6	0,2	17,1	0,2	17,1	-	0,1 (6 comp.)	0,2	<0,2
mineral oil type hydrocarbons (MOTH)	[mg/l]	0,1	3,1	0,1	3,1	0,1	3,1	0,1	6,5	0,1	6,5	-	-	0,2	<0,2

Please contact Freytech Inc. for arsenic filtration.

ecoStorm plus 1000 technical data

ecoStorm plus 1000 traffic (item no. 103085)

Drainage Area: 750m²

Slightly polluted traffic areas (side streets, staff car parks, yards)

Pipe dimensions: DN 200mm (8")

Number of Filter segments: 4

Housing material: Polyethylene; Weight: 86kg

Replacement filter; Weight: 34kg/segment

ecoStorm plus 1000 metal (item no. 103603)

Drainage Area: 650m²

Roofs made of uncoated metals (copper, zinc, lead)

Pipe dimensions: DN 200mm (8")

Number of Filter segments: 4

Housing material: Polyethylene; Weight: 86kg

Replacement filter; Weight: 66kg/segment

ecoStorm plus 1000 roof (item no. 103349)

Drainage Area: 1000m²

Roofs without a significant proportion of uncoated metals (<50m²)

Pipe dimensions: DN 200mm (8")

Number of Filter segments: 4

Housing material: Polyethylene; Weight: 86kg

Replacement filter; Weight: 34kg/segment

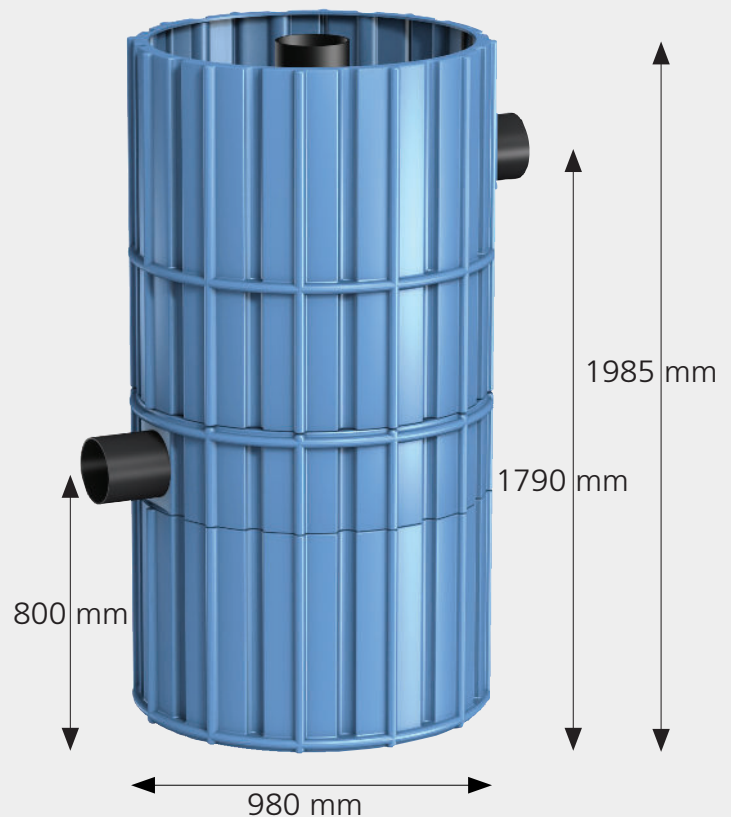

ecoStorm plus 1000 heavy traffic (Item no. 103214)

Drainage Area: 500m²

Highly polluted traffic areas (car parks in front of supermarkets, main roads, HGV access roads)

Pipe dimensions: DN 200mm (8")

Number of Filter segments: 4

Housing material: Polyethylene; Weight: 86kg

Replacement filter; Weight: 54kg/segment

Replacement filters

The ecoStorm plus 1000 filter elements should be checked every 2 years and should be changed if necessary.

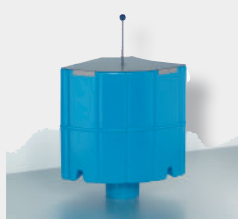

Filter element heavy traffic/metal

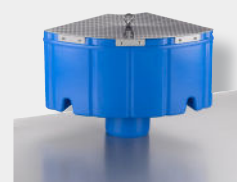

Filter element roof/traffic

Important Installation Instruction

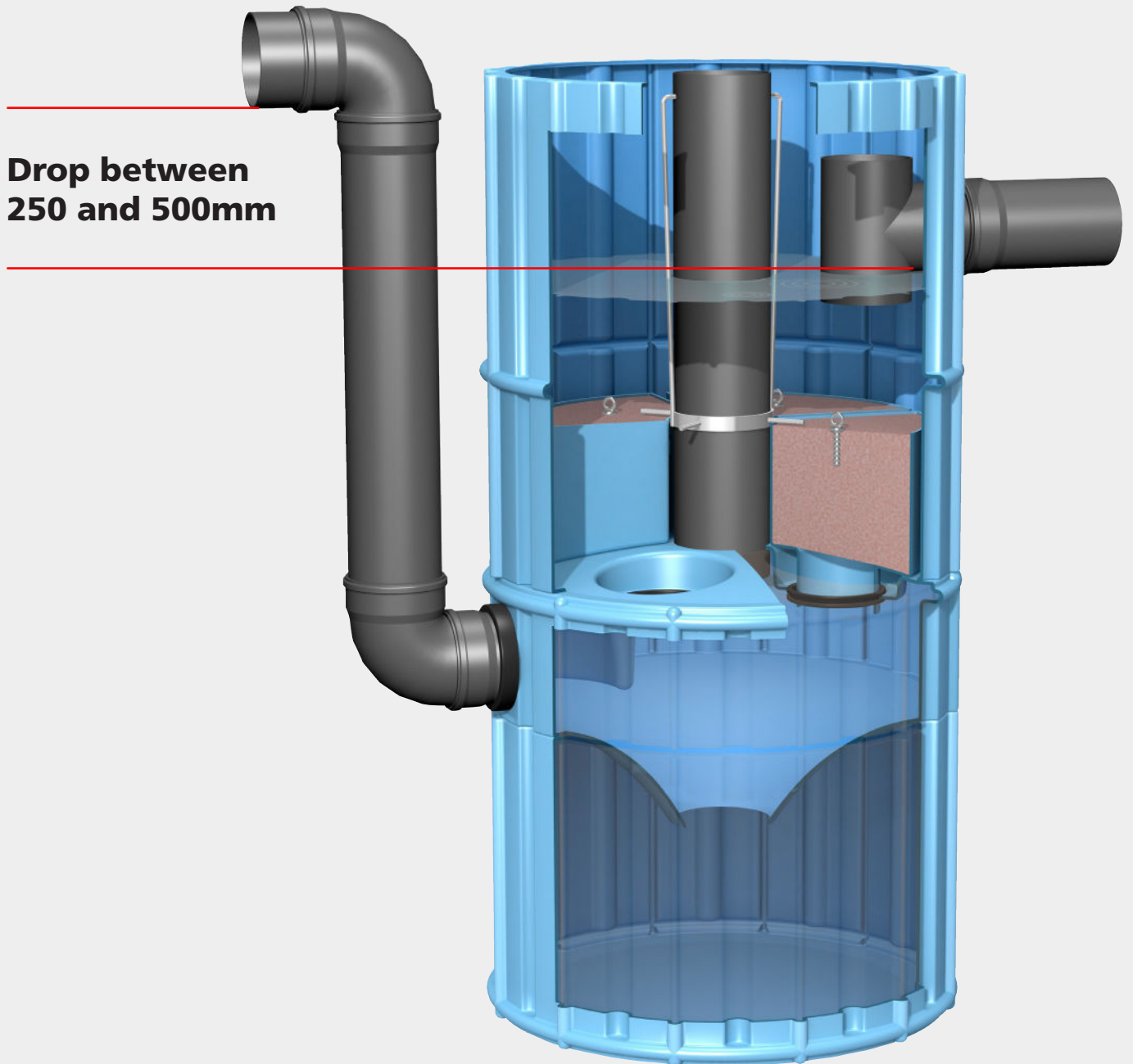

Freytech Inc.

1111 Brickell Avenue, Suite 1550, Miami, Florida 33131, USA

Phone.: +1 (305) 372-1104 Fax: +1 (305) 328-9312

e-mail: info@freytech.com, www.freytech.com

FREYTECH INC.